

Архангельск (8182)63-90-72
Астана (7172)727-132
Астрахань (8512)99-46-04
Барнаул (3852)73-04-60
Белгород (4722)40-23-64
Брянск (4832)59-03-52
Владивосток (423)249-28-31
Волгоград (844)278-03-48
Вологда (8172)26-41-59
Воронеж (473)204-51-73
Екатеринбург (343)384-55-89
Иваново (4932)77-34-06

Ижевск (3412)26-03-58
Иркутск (395)279-98-46
Казань (843)206-01-48
Калининград (4012)72-03-81
Калуга (4842)92-23-67
Кемерово (3842)65-04-62
Киров (8332)68-02-04
Краснодар (861)203-40-90
Красноярск (391)204-63-61
Курск (4712)77-13-04
Липецк (4742)52-20-81
Киргизия (996)312-96-26-47

Магнитогорск (3519)55-03-13
Москва (495)268-04-70
Мурманск (8152)59-64-93
Набережные Челны (8552)20-53-41
Нижний Новгород (831)429-08-12
Новокузнецк (3843)20-46-81
Новосибирск (383)227-86-73
Омск (3812)21-46-40
Орел (4862)44-53-42
Оренбург (3532)37-68-04
Пенза (8412)22-31-16
Казахстан (772)734-952-31

Пермь (342)205-81-47
Ростов-на-Дону (863)308-18-15
Рязань (4912)46-61-64
Самара (846)206-03-16
Санкт-Петербург (812)309-46-40
Саратов (845)249-38-78
Севастополь (8692)22-31-93
Симферополь (3652)67-13-56
Смоленск (4812)29-41-54
Сочи (862)225-72-31
Ставрополь (8652)20-65-13
Таджикистан (992)427-82-92-69

Сургут (3462)77-98-35
Тверь (4822)63-31-35
Томск (3822)98-41-53
Тула (4872)74-02-29
Тюмень (3452)66-21-18
Ульяновск (8422)24-23-59
Уфа (347)229-48-12
Хабаровск (4212)92-98-04
Челябинск (351)202-03-61
Череповец (8202)49-02-64
Ярославль (4852)69-52-93

<https://image.nt-rt.ru> || mgd@nt-rt.ru

F - SERIES

Finishing Equipment



● AMFEED

High quality feeder for a great variety of linens

AMFEED - S / PQ / Q

- S – Manual feeder
- PQ – 1 Station quality feeder
- Q – 2 Station quality feeder

STANDARD FEATURES:

- Suction box with brushes and guiding plates for stretching the sheet before laying down on the feeding bed
- Feeding bed is equipped with suction to keep the sheet fixated on the belts
- Multilane small pieces can be fed manually
- With horizontal spreading clips, which are tension adjustable per program, the sheet will be spread-out accurately
- With a speed adjustable lay down beam the sheet will be laid down on the feeding bed with high quality
- USB stick connection for backup of settings
- Acoustical warning alarm



● AMFLEX

AMFLEX – P / Q

- P – quality feeder for big linens
- Q – quality feeder for big and small linens

STANDARD FEATURES:

- The clips are height adjustable and ergonomically placed and start automatically
- With spreading clips which are servo controlled and tension adjustable per program, the sheet will be spread-out accurately
- Suction box with brushes and guiding plates for stretching the sheet before laying down on the feeding bed
- Feeding bed is equipped with suction to keep the sheet fixated on the belts
- With a speed adjustable lay down beam the sheet will be laid down on the feeding bed with high quality
- With the multilane small pieces unit, small pieces can be fed in manually
- USB stick connection for backup of settings





Image

Laundry Systems

F EEDER

● AMTRANS

STANDARD FEATURES:

- Sorting of sheets, duvets or draw sheets is possible without extra handling
- Also sorting of washed laundry into carriers at the clipping position
- Ergonomic workplace
- By buffering, the clipping production per person is fully independent of each other, contrary to a normal feeder, where the slowest person sets the pace
- Automatic or semi automatic sorting possibilities (sheets, duvets, draw sheets)
- The Amtrans automatically calls sheets from the rail system
- The feeder, ironer and folder automatically switch over to the right program and speed for handling different items
- USB stick connection for backup of settings



● ROBOFEED

Automatic Feeding Station for Sheets

STANDARD FEATURES:

- Feeding is possible directly from the conveyor belt after drying tumblers. The operator has to find only one corner of a sheet and feeds this corner with approx. 30 cm's sheet on a transport conveyor in a horizontal way
- The operator simply places the corner of the sheet on to a conveyor that is ergonomically positioned at hand height for ease of operation and optimum production. A production rate of 600 pieces/hour can be achieved
- After feeding, the sheet is transported vertically and the clips are then automatically clamped on the corners of the sheet.
- After the sheet is transported on the storage rail, it is fed to the feeding machine AMTRANS and then to the ironer automatically
- The ROBOFEED system provides the opportunity to automatically sort items according to sizes
- USB stick connection for backup of settings





● AMCLIP - CLIPPING STATION

Clipping station in Combination with an Amtrans feeder

STANDARD FEATURES:

- Ergonomic clipping station
- Combines with Amtrans high capacity feeder to process sheets, duvets, draw sheets and table linen
- The first clip is pulling the sheet, which makes it easier to find the second corner and reduces hard physical labor

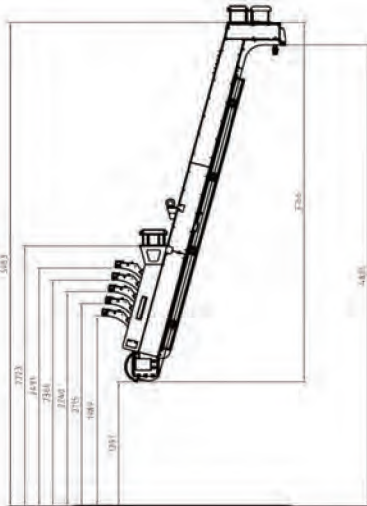



Image

Laundry Systems

SHEET **F**OLDER - STACKER

● **AMFOLD : SHEET FOLDER AND STACKER**

Automatic linen folding and stacking machine

AMFOLD - E / P / Q

- E – Economic sheet folder for sheets
- P – Standard sheet folder, all crossfolds with knife folds
- Q – Quality sheet folder, with various crossfolding, various crossfold speeds, all knife crossfolds

AMSTACK - C / D / M

- C – Stack and fold
- D – Drop stacker
- M – Multilane stack and fold for small pieces



STANDARD FEATURES:

- Automatic linen folding up to 5 lanes
- Up to 3 length folds
- Up to 3 cross folds possible with knife and reverse belts
- All cross folds timing belt driven for accurate folding
- Easy access in cross fold section
- Several cross fold combinations available
- Touch screen is self-programmable to set each piece to the correct program
- Possibility with multiple stackers and multilane stackers
- Able to connect with any ironer
- USB stick connection for backup of settings



● AMFOLD - B : BLANKET FOLDER AND STACKER

Automatic linen folding and stacking machine

AMFOLD - B : BLANKET FOLDER

FEATURES :

- Up to 2 lengthfolds
- Up to 3 crossfolds
- All cross folds timing belt driven for accurate folding
- Easy access in cross fold section
- Touch screen is self-programmable to set each piece for the correct program
- Available with spreading clips
- USB stick connection for backup of settings



● AMVERSA : REVERSE FOLDER

STANDARD FEATURES:

- Automatic linen folding up to 5 lanes
- 2 length folds (up to 3 length folds), with reverse folding with air
- Up to 3 crossfolds all by knife 1 or 2-lane
- All cross folds timing belt driven for accurate folding
- Easy access in cross fold section
- Automatic operation
- Able to connect with any ironer
- Touch screen is self-programmable to set for each piece the correct program
- Several cross fold combinations available
- Possibility with multiple and multilane stackers
- USB stick connection for backup of settings



● STF : TOWEL FOLDER AND STACKER

For folding and stacking a great variety of towels

STANDARD FEATURES:

- The first and second length fold of the STF are executed by belt reverse fold with blowpipe. After the two length fold, one cross fold is made combined with stacking
- With the above combination we can make one or two length folds with one crossfold and stacking
- One, two or three stackers are available in the STF. The different towels can be sorted automatically to two or three different stackers. The standard STF can be with a buffer conveyor that can transport folded towels back to the STF operator or other or other finishing point
- Touch screen is self-programmable to set for each piece the correct program
- USB stick connection for backup of settings



● MTF : TOWEL FOLDER

Automatic folding, sorting and stacking for large variety of mixed articles

STANDARD FEATURES:

- With suction in the feeding table, the towel is fixated before feed into the towel folder
- The length fold is automatic, depending on towel size, and made by French folding with knives
- 1 or 2 crossfold by knife and /or air, with reverse belts
- The towels will be sorted and stacked on 3 positions automatically
- Touch screen is self-programmable to set each piece the correct program
- Collecting conveyor available for transferring the stacked towels
- USB stick connection for backup of settings



● MTF : TOWEL FOLDER

Automatic folding, sorting and stacking for mixed articles

MTF - E / P

- E- Primary French fold with air
- P - Lengthfold is with knife

STANDARD FEATURES:

- With suction in the feeding table, the towel is fixated before feed into the towel folder
- The length fold is automatic, depending on towel size and made by French folding, with air
- 1 or 2 Cross fold by reverse belts and air
- The towels will be sorted and stacked on 3 or 4 positions automatically
- Rolloff stackers 3 or 4 positions
- Touch screen is self-programmable to set for each piece the correct program
- USB stick connection for backup of settings



OTHER PRODUCT

● AMPICKER - SHEET SEPARATOR

STANDARD FEATURES:

- Fully automatic operation
- Up to 1700 sheets/hour
- Touch screen
- Up to 100 programs
- USB stick connection for backup of settings
- Working with conveyor and/or bag systems
- Double picker
- High speed separator conveyor
- Pull height adjustable





Image

Laundry Systems



OTHER PRODUCT OF FINISHING EQUIPMENT

● AMSCAN - LAUNDRY INSPECTION SYSTEM

STANDARD FEATURES:

- Can be mounted on every folding machine
- Sorting on color, stains, holes, rips and shape
- Up to 8 different colored products can be inspected in a lane
- Stable and low maintenance
- Touch screen interface
- Standard up to 4 lanes of operation, option for 8
- Automatic marker line detection
- Areas can be selected with different adjustments
- High price/performance ratio
- Different product settings possible per line



Evaluation for every scanned sheet.

Easy to recall sheets which are scanned.



Parameters can be set and directly evaluated.

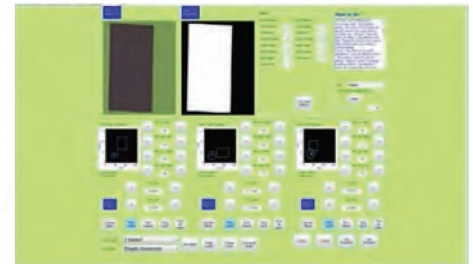

Easily fine tuning of the sensitivity.







Image

Laundry Systems

REFERENCES **F**-SERIES



Архангельск (8182)63-90-72
Астана (7172)727-132
Астрахань (8512)99-46-04
Барнаул (3852)73-04-60
Белгород (4722)40-23-64
Брянск (4832)59-03-52
Владивосток (423)249-28-31
Волгоград (844)278-03-48
Вологда (8172)26-41-59
Воронеж (473)204-51-73
Екатеринбург (343)384-55-89
Иваново (4932)77-34-06

Ижевск (3412)26-03-58
Иркутск (395)279-98-46
Казань (843)206-01-48
Калининград (4012)72-03-81
Калуга (4842)92-23-67
Кемерово (3842)65-04-62
Киров (8332)68-02-04
Краснодар (861)203-40-90
Красноярск (391)204-63-61
Курск (4712)77-13-04
Липецк (4742)52-20-81
Киргизия (996)312-96-26-47

Магнитогорск (3519)55-03-13
Москва (495)268-04-70
Мурманск (8152)59-64-93
Набережные Челны (8552)20-53-41
Нижний Новгород (831)429-08-12
Новокузнецк (3843)20-46-81
Новосибирск (383)227-86-73
Омск (3812)21-46-40
Орел (4862)44-53-42
Оренбург (3532)37-68-04
Пенза (8412)22-31-16
Казахстан (772)734-952-31

Пермь (342)205-81-47
Ростов-на-Дону (863)308-18-15
Рязань (4912)46-61-64
Самара (846)206-03-16
Санкт-Петербург (812)309-46-40
Саратов (845)249-38-78
Севастополь (8692)22-31-93
Симферополь (3652)67-13-56
Смоленск (4812)29-41-54
Сочи (862)225-72-31
Ставрополь (8652)20-65-13
Таджикистан (992)427-82-92-69

Сургут (3462)77-98-35
Тверь (4822)63-31-35
Томск (3822)98-41-53
Тула (4872)74-02-29
Тюмень (3452)66-21-18
Ульяновск (8422)24-23-59
Уфа (347)229-48-12
Хабаровск (4212)92-98-04
Челябинск (351)202-03-61
Череповец (8202)49-02-64
Ярославль (4852)69-52-93